

*Picture note: Inclusive different options*

## Auger filler AF

---

### Features:

- Volumetric dosing
- Stainless steel hopper with level sensor
- Independent driven mixing and equalizing paddle
- Screw based on product variables
- Screw closing valve to avoid unneeded product drop
- Electronics mounted in a stainless steel cabinet
- All product contact parts made of food grade materials

## Technical data:

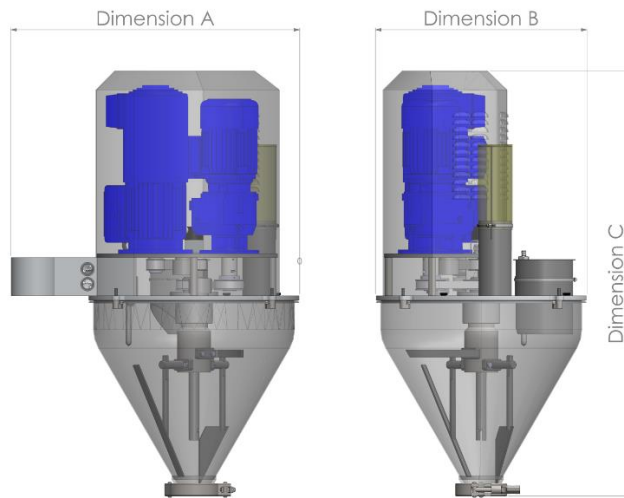

### AF-37

<i>Weight</i>	150 kg
<i>Dimension A</i>	800 mm
<i>Dimension B</i>	600 mm
<i>Dimension C</i>	1200 mm

- Electrical connection: 3 phase 400VAC + N + Pe
- Pneumatic connection: >6 bar at connection machine, clean and dry air

## Advantages:

- Compact and hygienic design
- Stand-alone installation or integration in automatic packaging lines
- Easy to operate
- Accurate filling

## Optional:

- Gravimetric dosing
- Atex
- Platform provided with rollers
- Platform provided with driven belt
- Height adjustable platform
- Dust suction pipe
- Bag clamp unit
- Height adjustable feet for mounting on VFFS
- Screw sizes on request